





## HOSE CLAMPS

### MATERIAL :

The material used in band and housing is low carbon steel as per specifications derived by I.S.I. The screw is manufactured from free cutting steel confirming to its standard grades.

The material used in the manufacturing of 'JOLLY' brand clamps are procured from well reputed manufacturers with quality assurance test certificates.

### FINISH :

The various parts of the clamp are given a smooth, polished finish and are free from rough and sharp throbbing edges. All the parts of the clamp are zinc plated with yellow passivation meeting to I S specifications.

The Jolly hose clamp is a multi-utility clamp specially designed to cover a wide range of diameters suitable to meet multiple utility areas. They are specially designed for reliance in withstanding HIGH PRESSURES and HIGH STRESSES. JOLLY CLAMPS are given a unique Space saving symmetrical design making it highly suitable for installation where limited space is available.

### EXAMPLE :

ITEM NO. 2A: 38-50

JOLLY SIZE NO. 2A

(This is as per IS 4762 : 50)

CLAMPING RANGE. 38- 50 This means it is suitable for diameters between 38 mm. And 50 mm. However if the clamps are used for other than the specified range then proper functioning as desired may not be obtained.

### DIMENSIONS FOR 'JOLLY' WORM DRIVE CLAMPS.

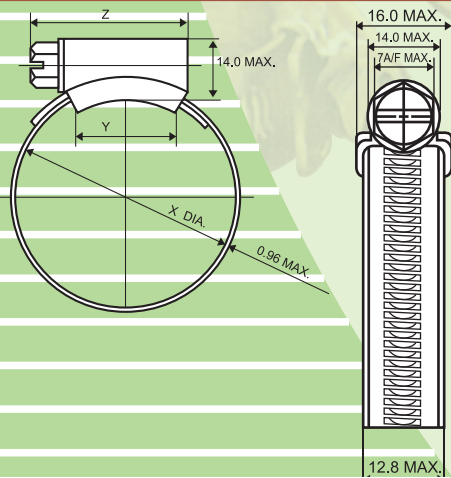

### JOLLY CLAMPS ARE SPECIALLY ADVANTAGEOUS LIKE....

- Every individual JOLLY CLAMP is punched with a size stamp.
- JOLLY CLAMPS are supplied in conveniently sealed small carry bags to avoid counting errors and for easy distribution.
- JOLLY CLAMPS have evenly rounded bands, thus preventing damage to the pipe and minimizing personal injury to the people in assembly.
- JOLLY BRAND clamps are manufactured and tested with highly precise equipments to ensure superior quality.
- Rather than inferior quality spot welding, JOLLY CLAMP'S, housings and strips are riveted together so as to withstand high pressure and stress. This gives a smooth and non-throbbing finish for the assembly.
- Uniquely designed housing in best adaptable for different diameters of clamps to ensure better adjustability and uniform clamping.
- Well forged hexagonal screws allow the use of standard spanners as well as screwdrivers. Wherein precisely engineered screw allows friction free movement at a very low torque achieving a high degree of efficiency.

### CLAMPING RANGE (X)

SIZE AS PER I S 4762	JOLLY SIZE	SIZE AS PER B S 5315	MM		INCH		Y mm Max.	Z mm Max.	Min. Torque KgF/Cm	Min. Pressure KgF/Cm
			MIN.	MAX.	MIN.	MAX.				
12	000	12	9	12	3/8	1/2	13	23		
16	00M	16	12	16	1/2	5/8	13	23	46	
20	00	20	14	20	1/2	3/4	13	23		
22	0	22	16	22	5/8	7/8	13	23		14.1
25	100S	25	18	25	3/4	1"	16	30	58	
28	ox	-	20	28	3/4	1.1/8	16	30		
30	0	30	22	30	7/8	1.1/4	16	30		
35	1A	35	25	35	1	1.3/8	16	30		
38	1375	-	30	38	1.1/8	1.1/2	16	30	69	
40	1X	40	30	40	1.1/8	1.5/8	16	30		
45	45A	45	32	45	1.1/4	1.3/4	16	30		8.4
50	2A	50	38	50	1.1/2	1.7/8	20	33	81	
55	2	-	42	55	1.5/8	2.1/8	20	33		
60	2X	60	45	60	1.3/4	2.3/8	20	33		
70	3	70	50	70	2	2.3/4	20	33		
75	75A	-	55	75	2.1/4	3	20	33		
80	3X	80	60	80	2.3/4	3.1/8	20	33		
90	4	90	70	90	2.3/4	3.1/2	20	33		
100	4X	100	80	100	3.1/8	4	20	33		
110	110A	-	90	110	3.1/2	4.3/8	20	33		
115	5	-	95	115	3.3/4	4.5/8	20	33	92	4.2
120	5X	-	100	120	4	4.3/4	20	33		
130	6	130	110	130	4.3/8	5.1/4	20	33		
140	140A	-	125	140	5	5.1/2	20	33		
145	575S	-	125	145	5	5.3/4	20	33		
150	150A	-	135	150	5.1/2	6	20	33		
160	6X	160	140	160	5.5/8	6.3/8	20	33		

### BRANCHES

**AHMEDABAD :** Email : ahmedabad@halston.in

**SURAT :** Email : surat@halston.in

**VIJAYWADA :** Email : vijaywada@halston.in

**INDORE :** Email : indore@halston.in

**RAIPUR :** Email : raipur@halston.in



Building business with trust

(FORMERLY KNOWN AS HALSTON DISTRIBUTORS)

1st Floor, Dastur Bldg., 266, Perin Nariman Street,

Above Union Bank of India, Fort, Mumbai - 400 001 • M +91 73037 90030

Esales@halston.in • W www.halston.in